



## Undercounter Glasswasher **CO-402W**

### CO-402W Undercounter, High-temperature Glasswasher + Sanitizer



\*ENERGY SAVINGS

EFFI WASH

SOFT START

#### QUICK VIEW

|                                  |                             |
|----------------------------------|-----------------------------|
| Dimensions: W x D x H            | 18-1/2" x 20-5/8" x 28-1/8" |
| Weight : net/crated (lbs)        | 97 / 103                    |
| Voltage                          | 208-230V/1Ph/60Hz           |
| Total Power                      | 3.2 KW                      |
| Wash pump ( HP )                 | 1/3                         |
| Water Consumption Per Rack       | 0.53 Gal.                   |
| Water Consumption Per Hour (Max) | 15.9 Gal.                   |
| Water inlet temperature          | 120°F - 140°F               |

#### SHORT DESCRIPTION

Fagor EVO Concept glasswasher model CO-402W is a high-temperature unit with Effi Wash, Soft Start and Digital Controls.

The unit is constructed with ANSI 304 stainless steel. IPX4 - Protection against water jets on control panel. Built-in drain pump, detergent and rinse aid dispensers. Pressure gauge. 10 5/8" clearance.

Each unit comes standard with two (2) flat racks, one (1) cutlery container and one (1) supplement for dishes.

Fagor's Concept range of dishwashers combines features and benefits that only high-end ranges are offering, becoming in a product easy to use and efficient, with the most effective and robust technology prepared for the strongest usage of the market. Built in durable stainless steel with electromechanical components and simple controls with temperature display for a user-friendly operation.

#### Production:

30 racks/hour (rack size 16" x 16")

#### Functions and Benefits

- **Effi Wash:** Optimized hydraulic system provides a strong mechanical action combined with the optimum clean water in the tank. Balanced power keeps the perfect sanitation temperature during the cycle of the wash.
- **Soft Start:** Wash-pump power control that prevents wares from damage at the beginning of the washing cycle while assuring a low noise level in your facility.
- **Digital Controls:** Simple digital control panel with temperature display for intuitive and user-friendly operation, IPX-4 proof.

#### Construction

- Heavy duty stainless steel construction front, top and sides.
- **Single skin door** to reduce noise during operations.
- AISI-304 Stainless.
- **IPX4** - Stronger protection against water hose cleaning and external humidity.
- Built-in **drain pump**.
- Built-in **pressure gauge**.
- Built-in **detergent and rinse aid dispenser**.

#### Accessories

- 16" x 16" Racks for glasses
- Cutlery containers and grids
- 6" & 16" high base stands
- Drain tempering valve



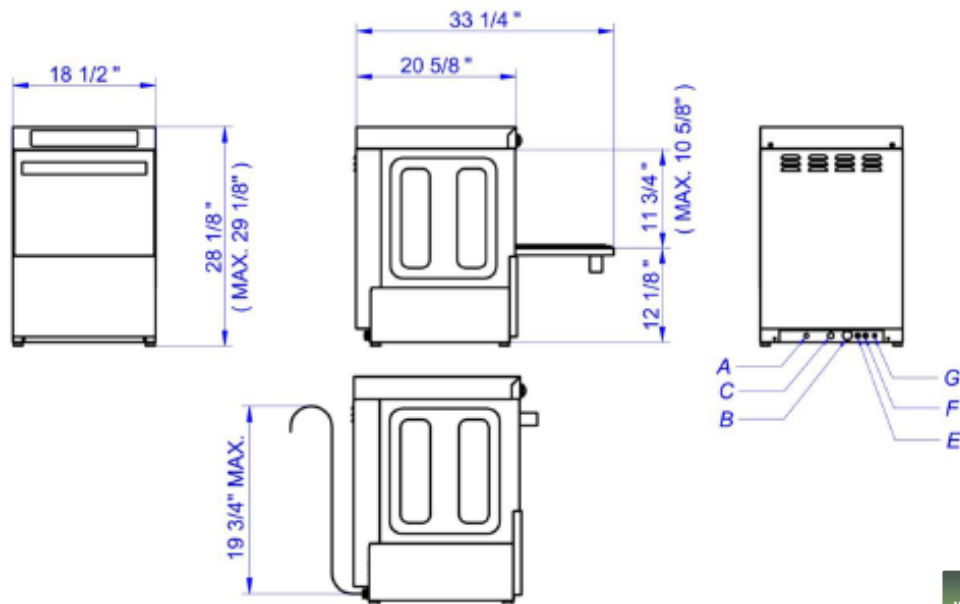

| A   | B             | C                                     | E               | F               | G                      |
|---|---------------|---------------------------------------|-----------------|-----------------|------------------------|
| Water inlet *   | Drain hose ** | Power supply cable, strain relief *** | Rinse aid inlet | Detergent inlet | Equipotential bond**** |
| <p>* Water inlet 3/4" female hose connector on 5' long flexible hose supplied with machine. Adaptor for 3/4" female garden hose fitting also supplied. 120°-140°F optimum water temperature; 20 -25 psi flow rinse pressure.<br/>           ** Drain 5' long, 1/2" I.D. flexible hose. Maximum 26 3/4" drain height permits indirect connection to drain pump.<br/>           *** 6' Long power cord supplied with machine (NEMA 6-20P)<br/>           **** Protection from dangerous potential differences</p> |               |                                       |                 |                 |                        |

| SPECIFICATIONS                    | CO- 402W        |          |
|-----------------------------------|-----------------|----------|
| Wash Cycles (seconds)             | 90-120-180      |          |
| Productivity (*)                  |                 |          |
| Racks/hour                        | 30              |          |
| Dishes/hour                       | 750             |          |
| Glasses/hour                      | 1080            |          |
| Standard Rack size (inches)       | 15 3/4 x 15 3/4 |          |
| Weight : Net/Crated (lbs)         | 97 / 103        |          |
| Dimensions (inches)               |                 |          |
|                                   | Unit            | Shipping |
| Width                             | 18 1/2          | 21       |
| Depth                             | 20 5/8          | 26       |
| Height                            | 29 1/8          | 35       |
| Useful Loading Height (clearance) | 10 5/8          |          |
| Capacity (gallons)                |                 |          |
| Wash Tank                         | 4.0             |          |
| Boiler                            | 1.05            |          |
| Water consumption per cycle       | 0.53            |          |
| Noise level (dBA)                 | <70             |          |

(\*) Assumed 25 dishes and 30 glasses per rack.

| SPECIFICATIONS                  | CO-402W |  |
|---------------------------------|---------|--|
| Wash pump motor ( HP )          | 1/3     |  |
| Power (kW)                      |         |  |
| Tank heating element            | 2.18    |  |
| Boiler/Booster heating element  | 3.05    |  |
| Wash pump(s)                    | 0.28    |  |
| Total power                     | 3.2     |  |
| Minimum Working Temperature     |         |  |
| Washing (°F)                    | 150     |  |
| Rinsing (°F)                    | 180     |  |
| AMP for 60 Hz                   |         |  |
| Volts                           | 1 Phase |  |
| 208                             | 12.03   |  |
| 220                             | 12.73   |  |
| 240                             | 13.88   |  |
| Water Protection Rating         | IPx4    |  |
| Detergent & rinse aid dispenser | •       |  |
| Drain pump                      | •       |  |
| Power cord supplied             | •       |  |

The manufacturer reserves the rights to modify materials and specifications without notice.