

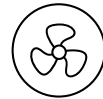



Available  
March  
2020



## Drying

¿Good-looking or effective?  
¿Robust or easy to maintain?  
Why not have it all?

We know that you seek continuous improvement in your processes. That is why we are committed to innovation, so that we can offer you products that meet your expectations. We present our new range of dryers with a new appearance, which facilitates use and maintenance and lengthens their useful life.



Large capacity

Low and medium capacity

**Optimum efficiency,  
optimum care.**



Self-service

Dryers  
Stack

Heat pump

We present the new Fagor Industrial KARE generation of dryers. An advanced and complete series of machines designed to provide the best solution for you, because KARE cares about what is most important to you; KARE cares about the world we live in, our environment. In Fagor we care about what really matters.

With the new KARE generation we have made sure that we put all its innovative features to your disposal. The second generation Touch Plus Control (TP2) is user friendly and guarantees the ultimate care for your clothes. Our machines have been ergonomically designed and components have been precisely placed for the easiest maintenance.

KARE cares about you and the environment. With a complete and concise set of features that provide an outstanding efficiency in terms of energy and water consumption KARE protects the world we live in.

Available  
March  
2020

## Characteristics by range

RANGE			ADVANCE+	ADVANCE	CONCEPT	ECONOMIC LINE
<b>TOUCH PLUS CONTROL</b>	Touch Plus Control	Touch Plus Control "TP2".	•	•	-	-
<b>EASY CONTROL</b>	Easy Control	Easy Control "M".	-	-	•	•
<b>AUTOREVERSE DRUM</b>	Reverse rotation drum	All models offer reverse rotation of the motor. In this way, the drying process is more efficient and offers a greater uniformity in the clothes drying process.	•	•	•	•
	Inverter	The reverse rotation drum system is performed by the inverter in all models.	•	•	•	•
	External body with a grey coating		•	•	•	-
	White external panels		-	-	-	•
<b>STAINLESS STEEL DRUM</b>	Stainless steel drum	The Advance and Advance Plus drums are manufactures from stainless steel, for greater quality and durability.	•	•	•	-
	Galvanised drum		-	-	-	•
<b>SOFT TOUCH</b>	Soft Touch	The new drum perforations guarantee the gentle treatment of clothing, thus prolonging their useful life.	•	•	•	-
<b>MIXED FLOW</b>	MIXED airflow (Axial+Radial)	The mixed axial-radial airflow system increases the efficiency of the whole drying process thanks to improved airflow within the drum.	•	•	•	-
<b>TOTAL FLOW</b>	Total Flow (optimised TOTAL axial+radial airflow)	Optimised mixed airflow (axial+radial)	•	-	-	-
	Radial airflow		-	-	-	•
<b>IDRY</b>	IDRY moisture control Intelligent iDry	Moisture detection system that, as well as the standard function of these systems, includes a drum speed control based on the level of moisture present.	•	○	-	-
<b>GREEN FLOW SYSTEM</b>	Green Flow (Air recirculation system)	Allows air to be reused in order to save more energy and improve airflow.	•	-	-	-
<b>DOUBLE SKIN</b>	Double Skin	Complete thermal insulation of the machine for improved energy efficiency.	•	-	-	-
	Double-glazed door		•	○	○	○
<b>FK SYSTEM</b>	Fire Kare System	The integrated fire prevention system provides maximum security and immediate activation of the system in case of a fire inside the dryer basket.	•	○	-	-
	Dosing System Vaporiser (softeners/perfumes)		○	○	-	-

• Standard

○ Option - Not available

# Two types of control

## TOUCH PLUS CONTROL

01.

A new fully programmable microprocessor with 20 preset programmes that can be modified during operation, and the option to create, export and import new programmes (USB).

The Advance Plus range includes a 7-inch touchscreen that is very intuitive and easy to use, 37 available languages and a USB port for software updates. In the Advance range, the screen is 4.3 inches for dryers of 11 to 35 kilos and 7 inches for models from 45 to 80 kilos.

The touchscreens on Kare dryers offer an innovative use that will increase income prospects for self-service laundries and also for individuals: advertising.

## EASY CONTROL

02.

The electronic brain included in the Kare range Concept dryers have buttons that control temperature (High, Medium and Low) and time in a simple, intuitive and economic way. There is also the option to programme the machine using an external console.

CONCEPT Economic-line

ADVANCE+ ADVANCE



FAGOR



# Built for you

## ERGONOMICS

01.

### Ergonomic

The Kare generation has been designed with user comfort in mind. That's why one of the factors in the design of this range was to equip all the dryers with the largest door dimensions on the market. Also, the direction of opening can be adjusted on the post (in the 11 to 35 kg models) by simply rotating the front panel and adding a longer cable. All models can have their doors adjusted to open in the opposite direction in the factory. This makes loading and unloading of the dryer easier and more ergonomic. Dryers also include a larger sized stainless steel lint filter which is more ergonomic and easy to clean.



## VERSATILE

02.

### Made To Measure

The Kare range offers the option of personalising the machines according to each customer's specific needs. Choose between the available options and we will deliver the machines to you with these options installed and tested in the factory.

03.

### Opl ↔ Self-service

The machines can be converted from OPL to Self-service and vice versa from the TP2 control. Models with Easy Control can also be converted.



04.

### Wet cleaning

Fagor offers you the most flexible solution on the market for putting a Wet Cleaning solution into practice. Machines are flexible; both washing machines and dryers offer the possibility of creating different programme phases with the custom parameters required by each supplier of wet cleaning industry detergent. It is a flexible business proposal, given that Fagor has previously cooperated with the most reputable chemical companies in the world, and has tested programmes for specific detergents in advance. Therefore, you can continue to cooperate with your detergent supplier and the products will be immediately integrated into your Fagor Washing Machines.



Available  
March  
2020

INCREDIBLE CONSTRUCTION CHARACTERISTICS

05.

**Stainless steel drum**

The efficiently designed stainless steel drums in the Kare Concept, Advance and Advance Plus ranges provide superior quality and durability.

06.

**Soft touch**

In line with Fagor Industrial's effectiveness and sustainability standards, all dryers in the Kare range include a perforated drum that guarantees the delicate treatment of clothing and, therefore, extending their useful life.

07.

**Fire Kare system**

The fire prevention system is included in the ADVANCE PLUS range as standard, and is an option in the ADVANCE range of Kare generation dryers. It is instantly activated in case of fire within the dryer basket, providing users with maximum safety.

08.

**Automatic reverse rotation**

All models offer reverse rotation of the drum. This makes the drying process more efficient and it offers greater uniformity in the clothes drying process. It also prevents clothes from becoming tangled.

09.

**Frequency inverter**

The ABB Inverter system included in all models and sizes of dryers in the Kare range controls the rotation speed and the reverse rotation of the drum.

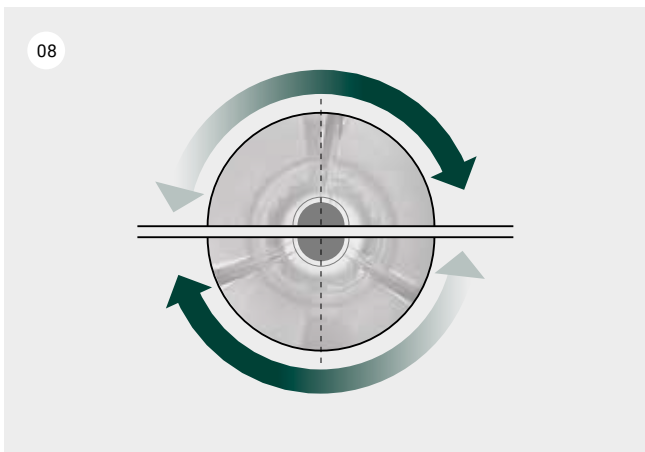
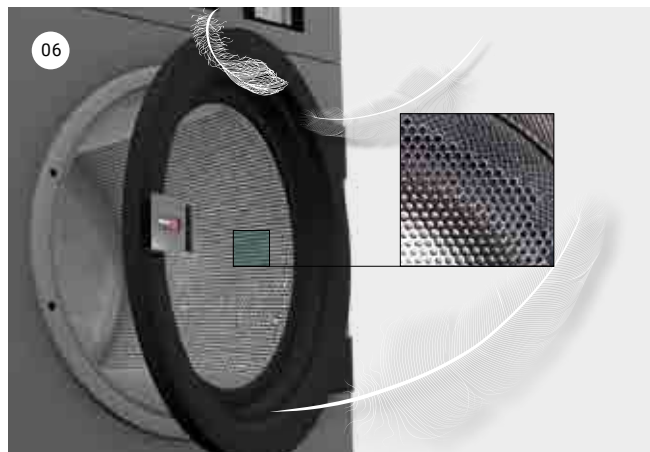

# Efficiency

01.

## Green flow system

To achieve maximum energy savings, we have created an air recirculation system that sends hot expelled air back into the drum.

The ADVANCE PLUS range reuses hot air, reducing the maximum drying cycle time and energy consumption.

02.

## iDry

The new FAGOR INDUSTRIAL moisture sensor, together with the temperature sensor at drum entry, offers precise control over the moisture levels of clothing. The system automatically stops the drying cycle as soon as the established residual moisture level has been reached. This avoids unnecessary prolongation of the drying cycle and the wear of clothing, while significantly reducing energy consumption. The fire prevention system is included in the ADVANCE PLUS range as standard, and is an option in the ADVANCE range.

03.

## Efficient airflow

All models offer a large, ergonomic lint filter and improved airflow. These features, together with the innovative stainless steel filter pan and the option to incorporate a larger than normal filter diameter (0.3 mm) provide increased drying efficiency.

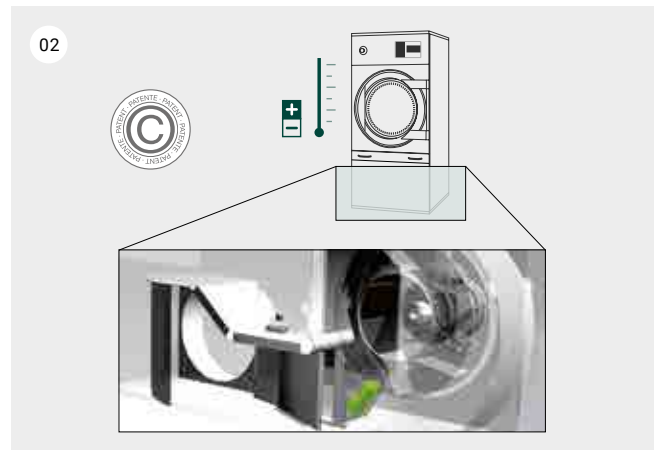
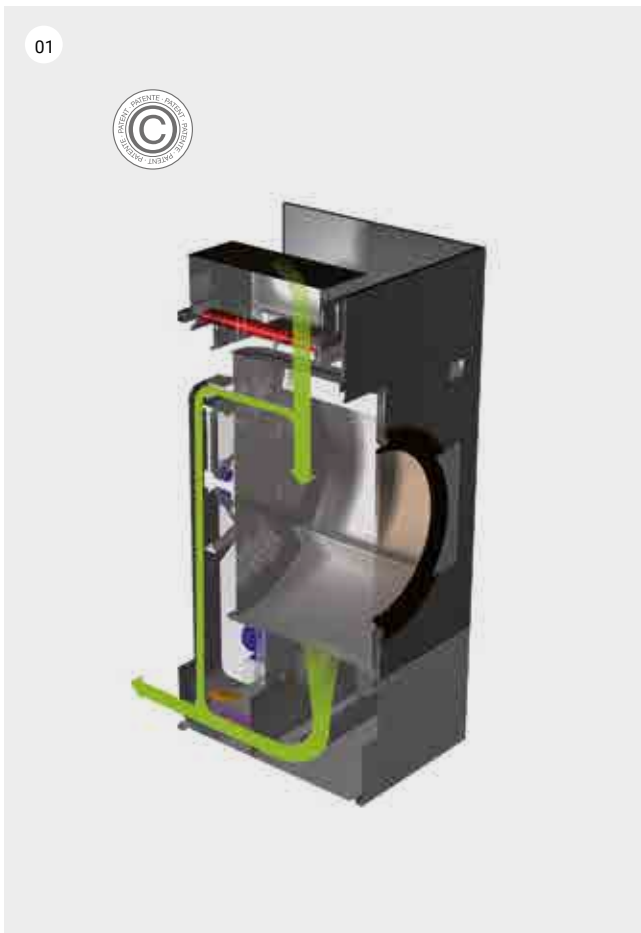

Available  
March  
2020

04.

### Mixed flow

The new axial-radial airflow system in the Kare range increases efficiency throughout the whole drying process thanks to improved airflow inside the drum.

05.

### Total flow

An innovative and optimised mixed airflow for Advance Plus dryers. The standard axial-radial airflow (mixed flow) is complemented by additional openings to optimised the air circuit and reach maximum efficiency.

06.

### Double skin

Complete thermal insulation of the airflow circuit to avoid the loss of heat to the outside: the drum, the panels in contact with the airflow, the recirculation piping and the double-glazed door. This optimises energy efficiency.

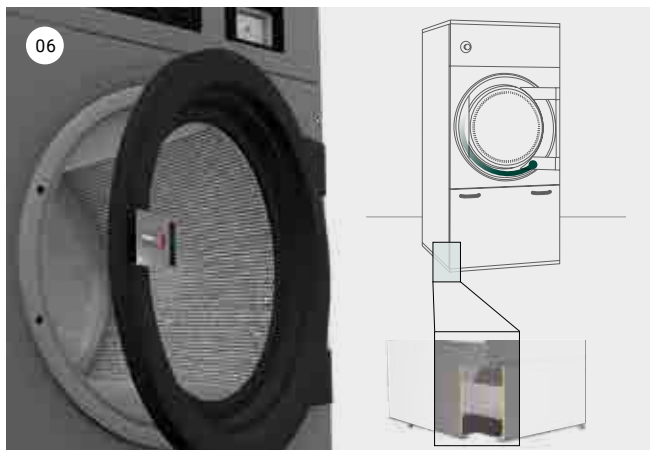
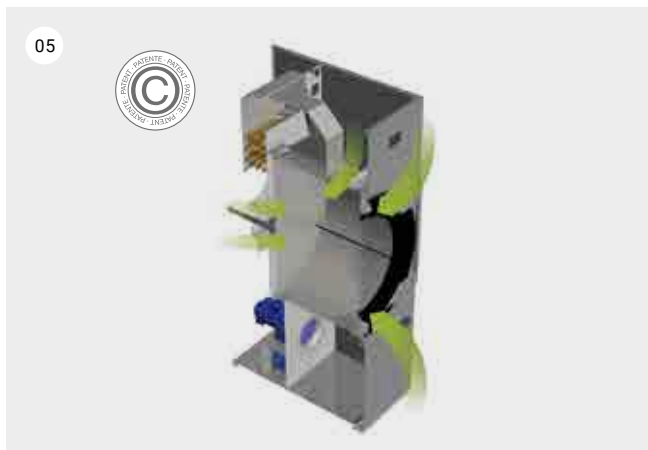
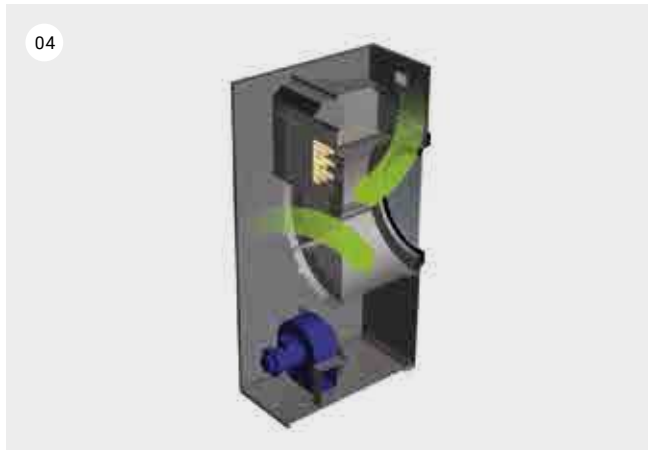





# Dryers

Advance + .....	092
— Low and medium capacity .....	094
— High capacity .....	097
Advance .....	099
— Low and medium capacity .....	101
— High capacity .....	104
Concept + .....	106
— Low and medium capacity .....	108
— High capacity .....	110
Economic Line .....	112
— Low and medium capacity .....	113

Special models or any other variant on the standard model are to be assembled in factory, and carry a supplement over the price indicated for the standard model.

Please consult Fagor Industrial for any other variant or option not reflected on this list.



FAGOR

4:14  
40°  
50°  
60°  
93  
30%  
01:40  
MULTI PLUS CONTROL

FAGOR

Available  
March  
2020

# Dryers.

Superior drying performance



ADVANCE+



ADVANCE



CONCEPT



Economic Line

The new design of Kare generation dryers allow unprecedented efficiency levels and position them as the most technologically advanced dryers on the market. With attractive aesthetics, we have achieved a machine image that is not in conflict with improved practicality for users and ease of maintenance.

At Fagor Industrial, we offer a diverse range of dryers, from single-drum dryers to stack dryers (double drum) and heat pump dryers. In addition, for each product type, it is possible to choose between different ranges that complete our product offering, and that allow us to adapt to every client type: from those looking for maximum performance and energy efficiency to those looking for a simple, economic dryer that is easy to manage and maintain. We have also incorporated a wide variety of accessories and features that will meet the different needs of every client.

# ADVANCE +



01.

## Green flow system

To achieve maximum energy savings, we have created an air recirculation system that sends hot expelled air back into the drum. The ADVANCE PLUS range reuses hot air, reducing the maximum drying cycle time and energy consumption.

02.

## Total flow

An innovative and optimised mixed airflow for Advance Plus dryers. The standard axial-radial airflow (mixed flow) is complemented by additional openings to optimised the air circuit and reach maximum efficiency.

03.

## Double skin

Double skin and a double-glazed door that provide a complete thermal insulation of the machine for improved energy efficiency.



Available  
March  
2020

Great control, greater efficiency.

Advance Plus range dryers are a good example of the company's commitment towards global environmental awareness. In the knowledge that dryers are the machines that consume the most energy in modern laundries, Fagor Industrial has created the ADVANCE PLUS range, which boasts one of the most efficient drying systems on the market. This range will not only contribute towards caring for the environment, it will also reduce your costs by up to 40%.

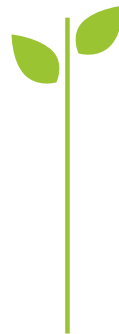

40%

Greater energy  
efficiency

Kits for **ADVANCE PLUS** dryers 11 - 16 - 23 - 28 - 35 kg

Kits available for incorporation into assembled machines.

SAP CODE	NAME OF CHARACTERISTIC	DESCRIPTION	MODEL					€
19072503	AF	Air inlet filter kit 11-16	11	16				-
19072510	AF	Air inlet filter kit 23			23			-
19072511	AF	Air inlet filter kit 28-35				28	35	-
19068044	PR	Printer kit	11	16	23	28	35	-
19072517	DS	Dosage kit	11	16	23	28	35	-
12146879	-	Turbo silencer kit ø200	11	16	23	28	35	-

\* Check prices at the list of accessories and spare parts.

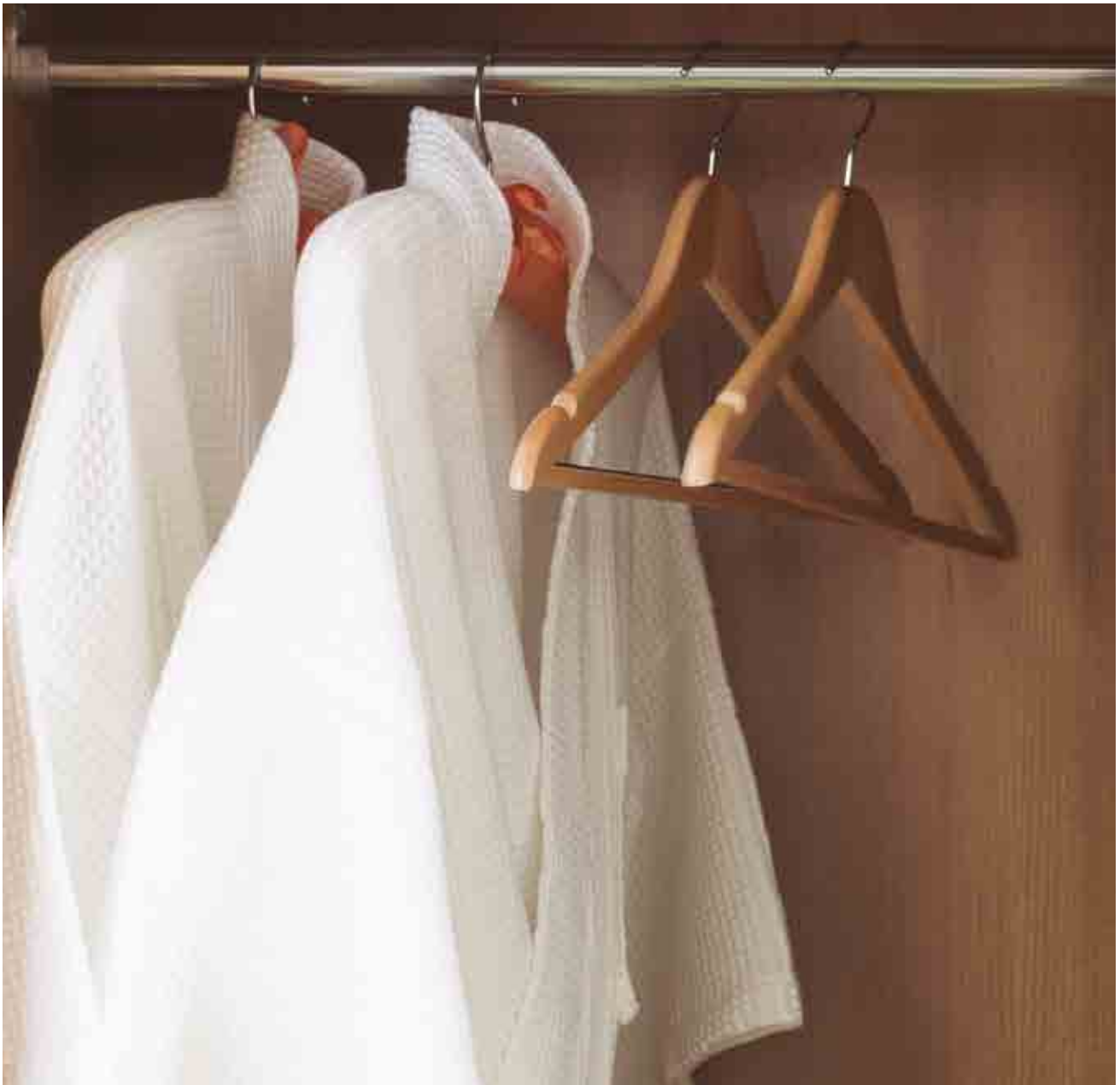

Available  
March  
2020

ADVANCE



01.

### Touch Plus Control TP2

The Advance Plus and Advance ranges incorporate a new fully programmable Touch plus control (TP2) that offers the possibility to create, export and import new programmes (USB). It includes a 7-inch touchscreen that is very intuitive and easy to use, 37 available languages and a USB port for software updates. The touchscreens on Kare dryers offer an innovative use that will increase income prospects for self-service laundries and for individuals: advertising.

02.

### iDry

The new FAGOR INDUSTRIAL moisture sensor, together with the temperature sensor at drum entry, offers precise control over the moisture levels of clothing. The system automatically stops the drying cycle as soon as the established residual moisture level has been reached. This avoids unnecessary prolongation of the drying cycle and the wear of clothing, while significantly reducing energy consumption.

03.

### Fire kare system

It is included in the Advance Plus range as standard, and is an option in the Advance range. It is instantly activated in case of fire within the dryer basket, providing users with maximum safety.

## Efficient technology, advanced drying.

The Advance range is ideal for those clients looking for high-performance, efficient and quality dryers. Advance machines meet all requirements a professional dreams of: latest control technology, robustness, advanced drying functions, and self-diagnostics to optimise maintenance times.



# CONCEPT



01.

## Easy control

The electronic brain included in the Kare range Concept and Economic Line dryers has buttons that control temperature (High, Medium and Low), and time in a simple, intuitive and economic way. There is also the option to programme the machine from a remote console. Optional screen to view time, temperature and programme (3 possible programmes). This also allows the technical menu to be accessed without the use of the console.

02.

## Mixed flow

The new axial-radial mixed airflow of the Kare range increases efficiency throughout the whole drying process thanks to improved airflow through the drum.

03.

## Stainless steel drum

The efficiently designed stainless steel drums in the Kare Concept, Advance and Advance Plus ranges provide superior quality and durability.

Available  
March  
2020

The perfect balance between quality and price.

Concept range machines are designed for those looking for the best, but with simple operation, without complications and easy maintenance. Models are equipped with high-quality functions as standard and they include EASY control.

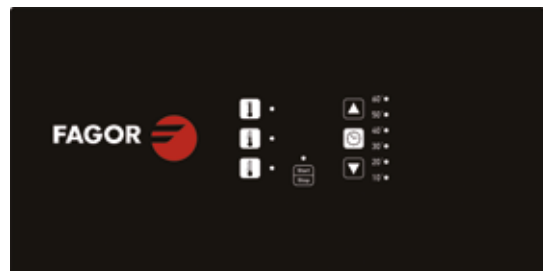

# Economic line

Simple and economic,  
with the same performance and robustness.



01.

## Quality at the best price

Designed for clients who need a cheaper dryer but without compromising on quality.

The range is available in sizes 11 to 23 kg.

The whole range is equipped with Economic Line frequency inversion and maintains the same drying performance and quality as other ranges.

02.

## Easy control

The electronic brain included in the Kare range Concept and Economic Line dryers has buttons that control temperature (High, Medium and Low), and time in a simple, intuitive and economic way. There is also the option to programme the machine using an external console.

Optional screen to view time, temperature and programme (3 possible programmes). The technical menu can also be accessed without having to use the console.

Available  
March  
2020









# Stack Dryers

Advance .....	119
Concept.....	119
Economic Line .....	119

Stack dryers

Special models or any other variant on the standard model are to be assembled in factory, and carry a supplement over the price indicated for the standard model.

Please consult Fagor Industrial for any other variant or option not reflected on this list.

# Stack dryers

Optimise space with stack dryers

Fagor double drum dryers are compact machines ideal for laundries with little available space and, while they have been designed with the self-service sector in mind, they are also available for hotels, small laundries, etc.

Equipped with all the characteristics of the ADVANCE, CONCEPT and ECONOMIC LINE models.

ADVANCE

CONCEPT

Economic-line



01.

## Versatility

With two drums and greater versatility thanks to two sets of controls, the new stack dryers offer a greater operating capacity and space optimisation.

02.

## Ease

There is one single connection and extraction tube. Installation and maintenance are therefore quicker and easier.

03.

## Self-service

This type of dryer is specially designed for the self-service sector.



**FAGOR COMMERCIAL, Inc.**

13105 NW 47th Avenue, Opa Locka, FL, 33054

T. (+1) 305 779 0170 | 866 GO FAGOR

info@fagorcommercial.com

www.fagorcommercial.com



ISO 9001

